



Twin Rotor Wind Turbine

TWind

The Challenge

Many electricity-intensive businesses outside residential areas – such as greenhouses, biogas plants, wastewater treatment facilities, industrial parks and local district heating networks – **want to power themselves with low-cost, clean electricity.**

Major obstacles:

- Traditional wind turbines: **too large, too expensive, too bureaucratic**
- **Space constraints** and strict **setback regulations**
- **High costs and effort** for grid connection, permitting, transportation, installation and maintenance
- Existing solutions are **not designed for flexible, on-site consumption**

The Market Opportunity

Organized energy users with privileged status for generating their own electricity outside municipalities

Germany

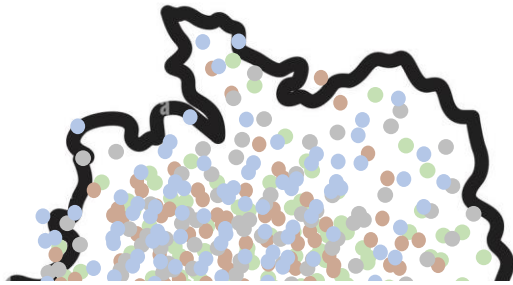

We know, where they are

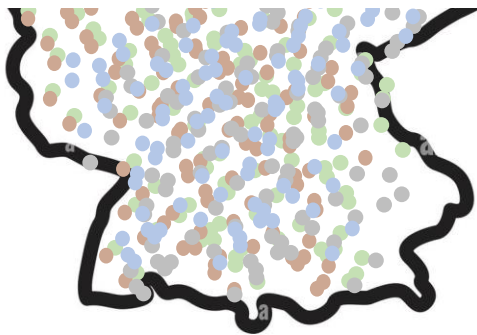

Local district heating networks to come up in the near future



Greenhouses



3000 ha



Biogas plant operators



9.800



Industrial zones



62000



Wastewater Treatment plants



9000

Wind Turbine Market



50m <100kw



TWind



RES-T Product Development

Existing 30 kW WT



WTG established on the market
Annual energy yield 45,000kWh

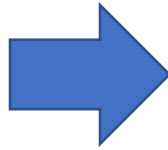

TWind 60 kW WT



Combination of existing WTGs with new support structure
Annual energy yield 100,000 kWh

Goal: Minimization of LCOE for WTGs with a maximum total height of 50 m

TWind as a cost-effective electricity supplier

- Optimum energy yield at locations with a height restriction < 50 m
- Simple and low cost installation/maintenance of the system because it takes place on the ground
- Lowering the rotors as required, e.g. before extreme wind events, allows for reduced loads and increased life time
- Easy transportation to the site thanks to small and lightweight system modules (container transport)

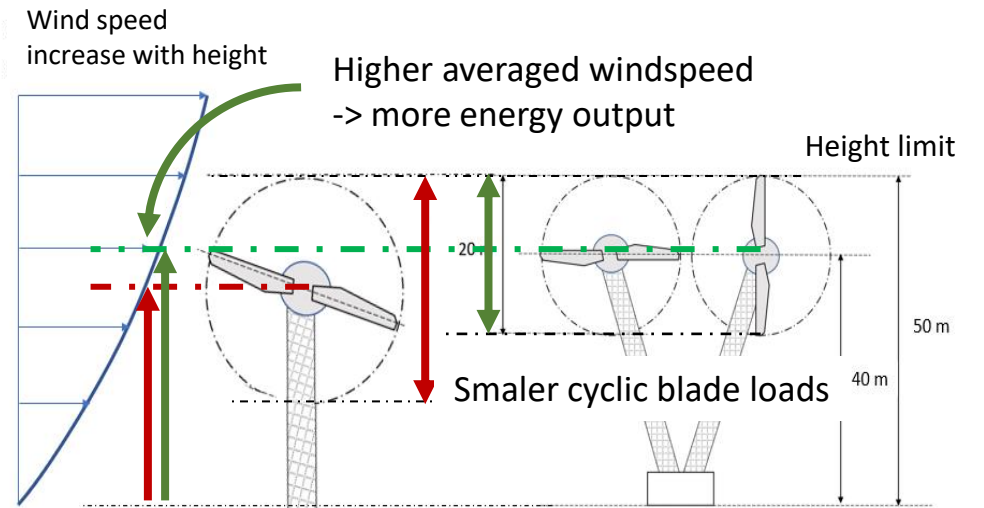

TWind 60

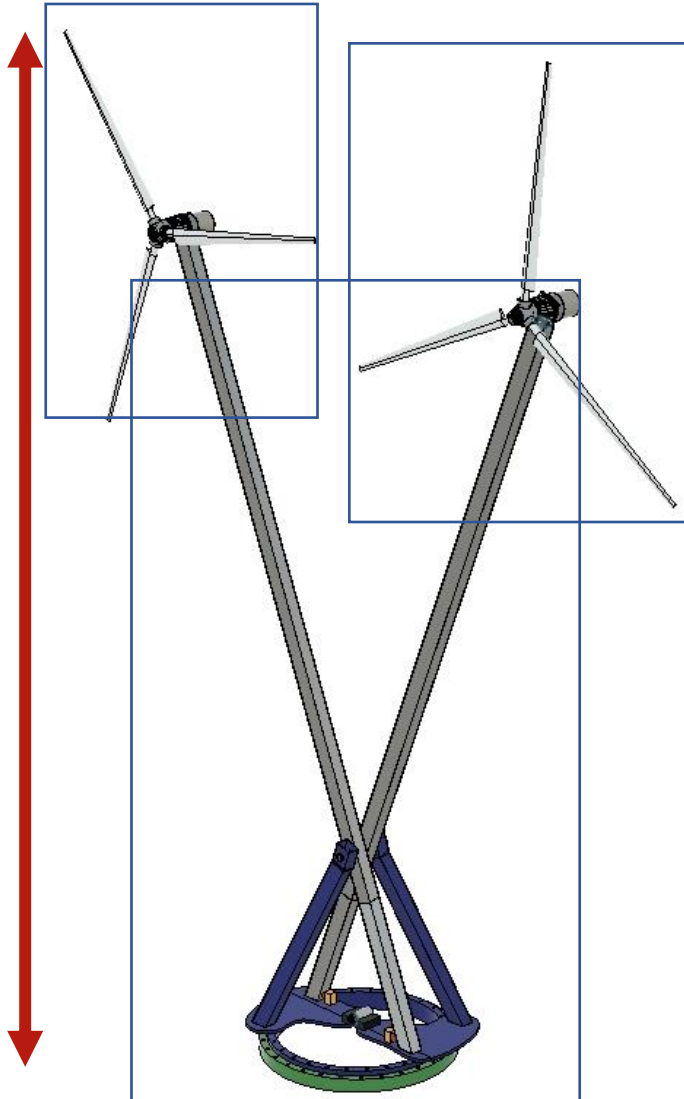

- Total height < 50 m
- 2 x 30 kW WTG variable-speed synchronous generators with full inverter
- **Modular lightweight structure with vibration control and automatic lifting system** Patent filed

TWind 60

Segmentable rotor blade design (as future option)

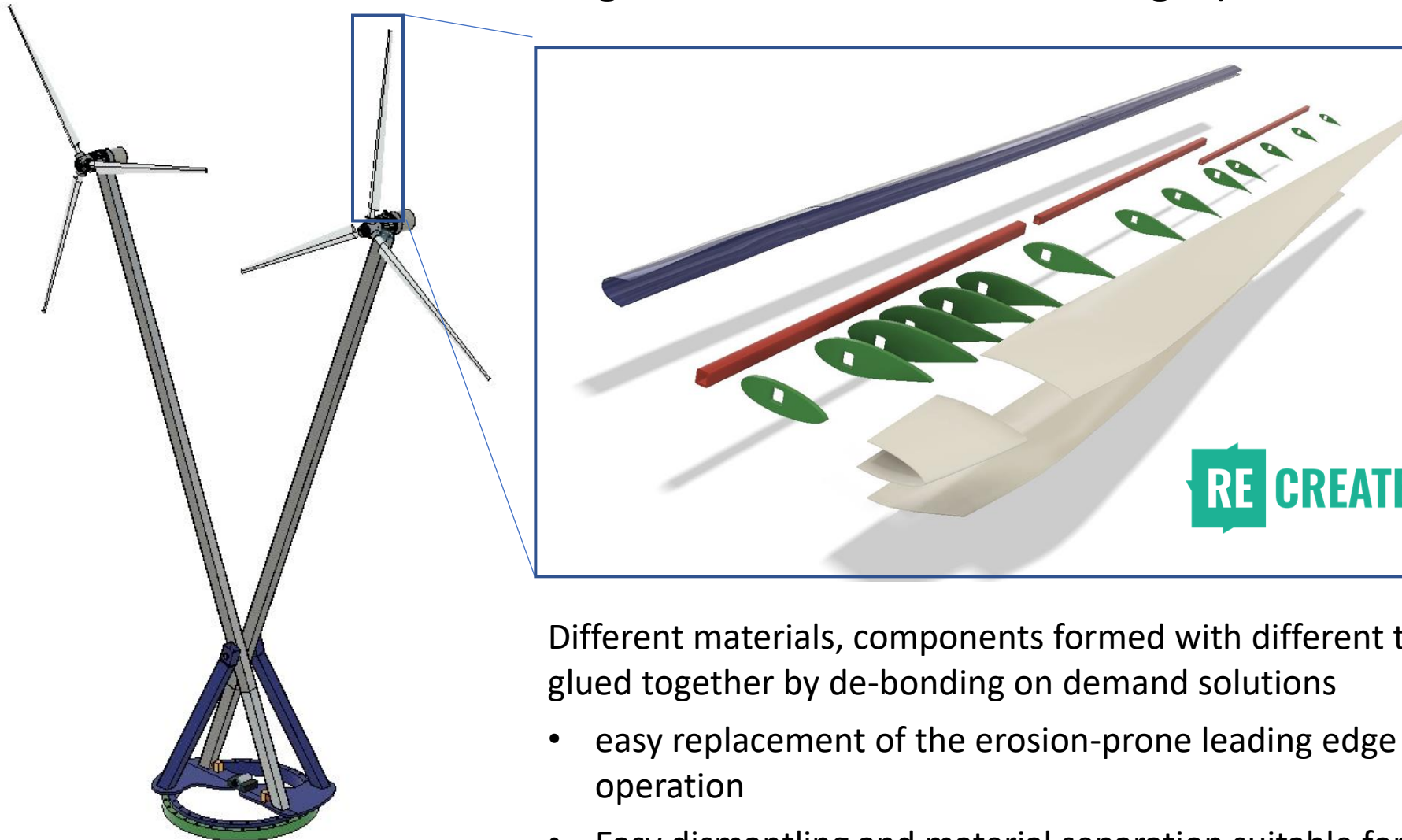

Different materials, components formed with different technologies glued together by de-bonding on demand solutions

- easy replacement of the erosion-prone leading edge during operation
- Easy dismantling and material separation suitable for recycling once the service life has been reached

TWind 4 kW Prototyp

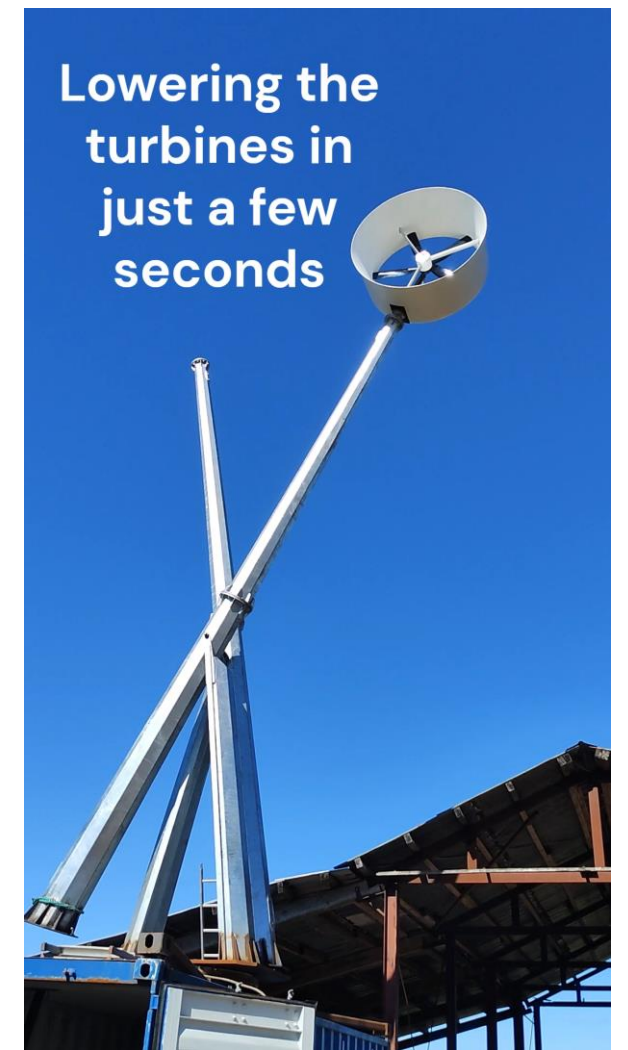
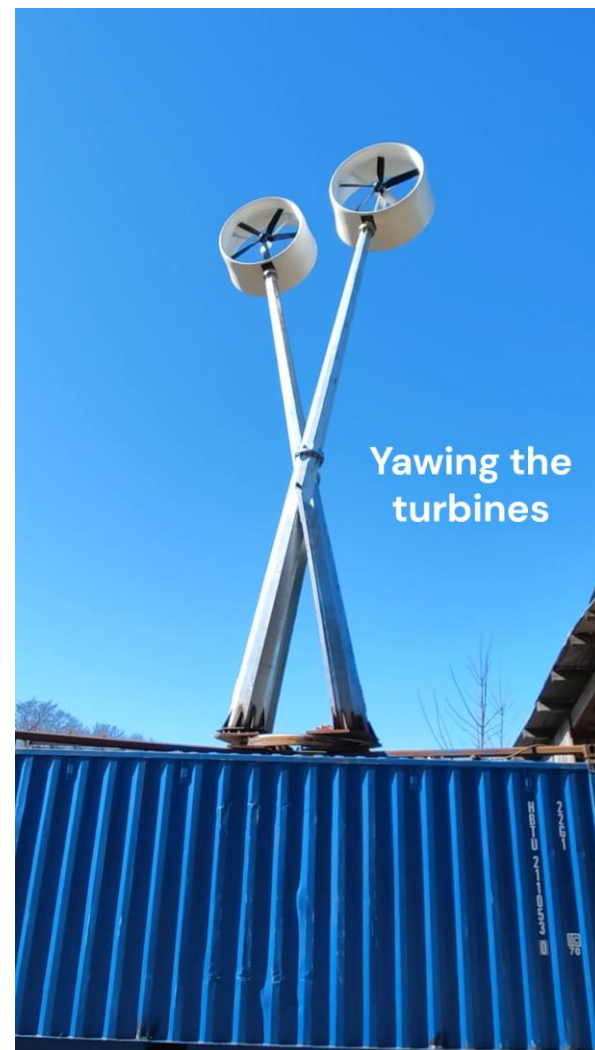
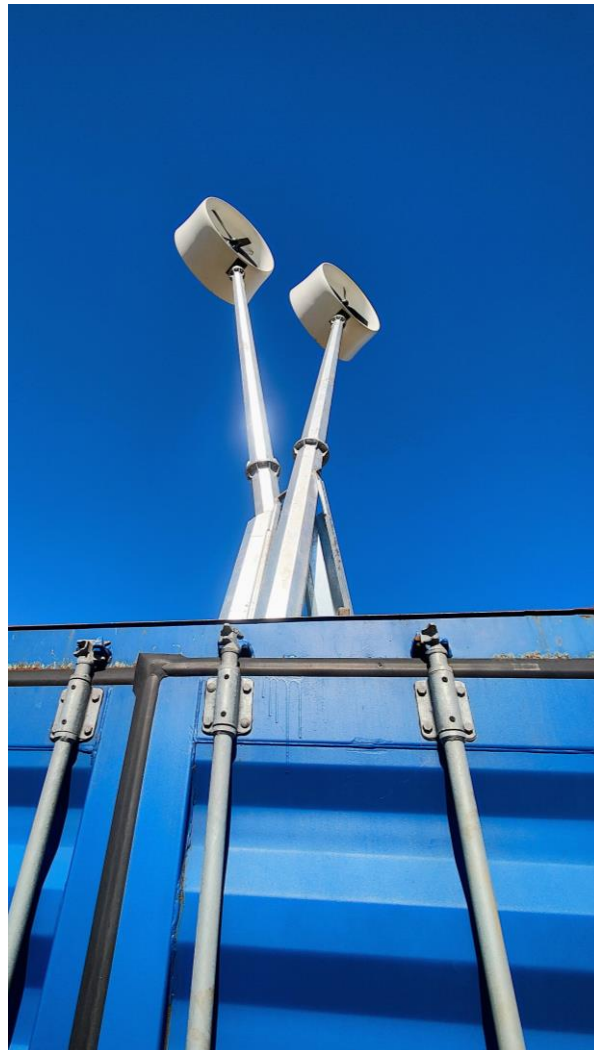

How do we want to ramp up

- Experience from 4kW TWind
- Development and Prototype TWind 60 (2-3 years)
- Sale of the RES-T Twind 60



Equity build-up for financing
investments in own operations

- Electricity revenue from the operation of own RES-T TWind 60 for consumers
- Licensing for foreign markets



TWind

by

RESIT

**Do you want to be part of it?
Investors/Partners welcome!**

Renewable Energy Container

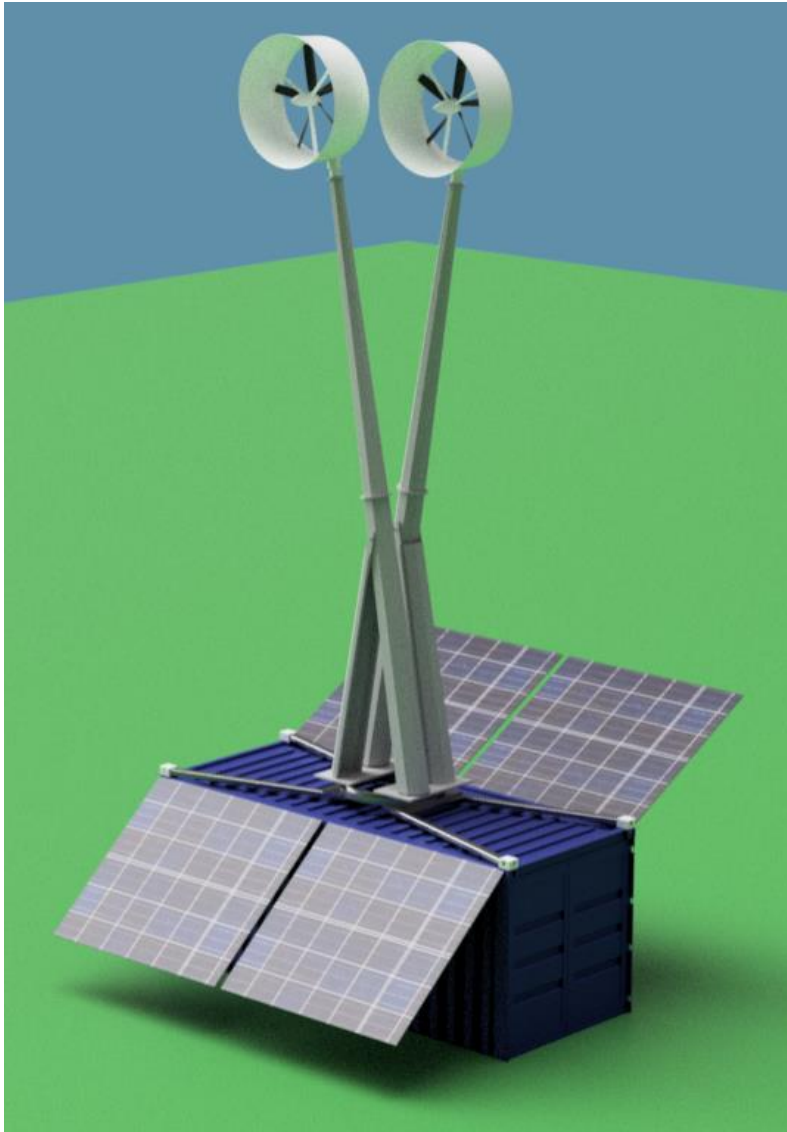

Container with (jacketed) turbines, PV and storage systems for:

- e-bike and vehicle charging stations
- supplying (electricity, cooling, heating) to built-in self-service machines
- “Supply Stations” for local authorities
- “Plant Containers”
- Marinas
- Schools
- Campsites
- Car parks (motorways, country roads)
- Open-air events (sporting events/music festivals, etc.)
- Military
- ...

